

CSF 컴펜세이팅 척 (보상형 척)

Compensating Chuck



SPECIAL CHUCK

- Jaws float on spherical bearing to determined clamping points
- Spring or fixed center available
- All three jaws apply constant gripping force

- 스프링 센터 나 고정센터 사용가능
- 각 조에 힘이 동일하게 전달되어 센터기준 고정 가능
- 구면에 의한 보상 구조로 정밀도가 우수

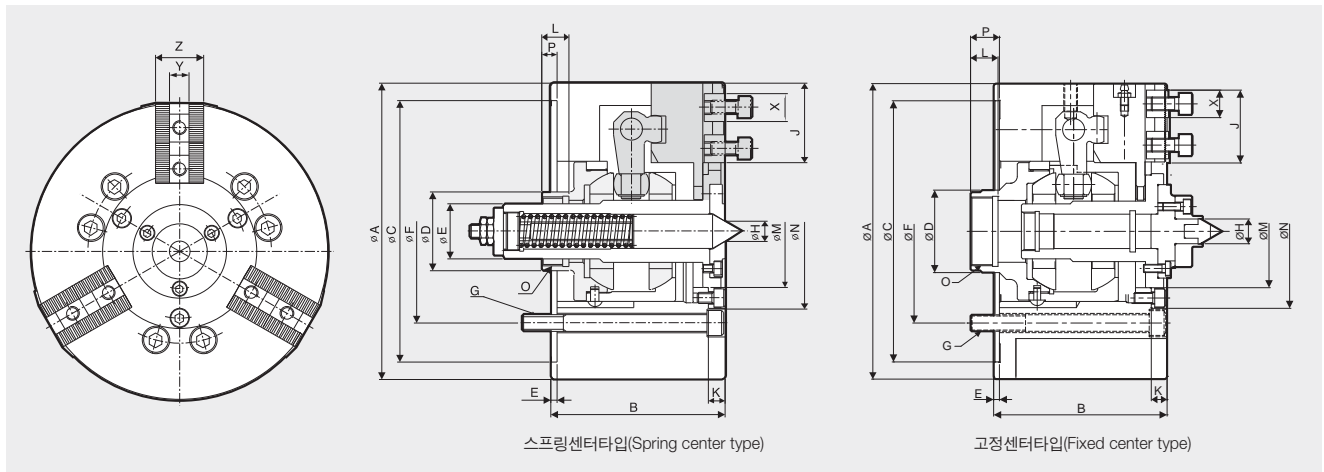

Dimensions / 치수표

	A	B	C(h)	D	E	F	G	H	J	K	L	M	N	O	Pmax.	Pmin.	X	Y	Z
CSF-07	170	99	140	42	4	104.8	3-M10	11	45	11	20	65	86	M34 X P1.5	28.2.	8.2	16	11	28
CSF-08	215	126.2	190	57	4.2	133.4	6-M12	15	57.5	13	20	82	112.1	M50 X P1.5	34	9	20	14	35
CSF-12	280	154.7	255	72	5.7	171.4	6-M16	20	72	17	26	110	142.2	M60 X P1.5	44	14	26	20	45

Specifications / 사양

	Static Clamping Force (kgf)	Max. Drawbar Pull (kgf)	Jaw Stroke mm(dia)	Plunger Stroke (mm)	Min Chucking Diameter (mm)	Max. Runout Diameter (mm)	Max. Speed (r.p.m.)	Spring Force (kgf)	Weight (kg)	GD ² (kgf·m ²)
CSF-07	2600	1500	16	20	20	4	4000	45	15	0.25
CSF-08	3200	2100	20	25	25	4	3200	52	28	0.8
CSF-12	4400	2700	25	30	30	6	2000	106	58	3.13