

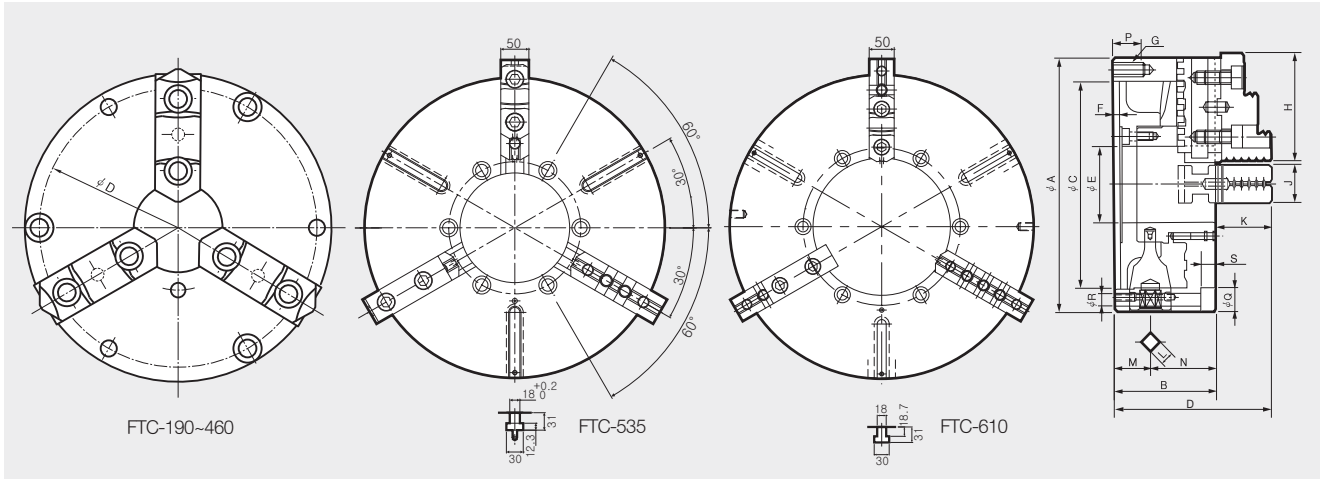

SCROLL CHUCK

- Front-mounting 2-piece jaw scroll chuck (incl. soft and hard top jaws)

- 전면 체결 스크롤척 (TC형과 동일 사양)



Dimensions / 치수표

	A	B	C(H6)	D	E	F	G	H	J	K	L	M	N	P	Mounting Bolt			
															Q	R	S	Bolt
FTC-190(7")	192	78.7	155	172	57	5	3-M10	80.5	28	42.8	11	27.5	51.2	20	16.5	10.5	10.5	M10
FTC-230(9")	232	83.7	190	210	75	6	3-M12	90.5	32	53.8	12	29.5	54.2	25	20	13	12.5	M12
FTC-273(10")	273	88	230	250	89	6	3-M12	103.5	35	57.82	12	31.5	56.5	25	20	13	12.5	M12
FTC-310(12")	310	96	260	285	100	7	3-M12	115.5	40	56.08	14	31.5	64.5	25	20	13	12.5	M12
FTC-460(18")	460	114	400	425	190	8	-	140(130)	50	80	17	38.2	76	-	26	18	18	6-M16X125
FTC-535(21")	535	143	270	235	195	12	-	150(130)	50	82	22	57.5	85.5	-	32	22	22	6-M20X140
FTC-610B(24")	610	143	380	315	216	14	-	150(130)	50	82	22	57.5	85.5	-	32	21	22	6-M20X140
FTC-610HA(24")	610	143	380	315	275	14	-	130	50	82	22	57.5	85.5	-	32	22	21	6-M20X140

Specifications / 사양

	Max. Static Gripping Force 최대정적파악력 KN (kgf)	Max. r.p.m 허용최고회전수 min ⁻¹ (r.p.m)	Weight 중량 kgf	GD ² N·m ² (kgf·m ²)	Gripping diameter 파악범위		Handle Torque 핸들토크 N·m(kgf·m)
					(External) φmm	(Internal) φmm	
FTC-190(7")	31 (3161)	3500	12.2	2.35 (0.24)	4~180	56~170	107.9 (11.0)
FTC-230(9")	37 (3773)	2900	21.2	6.27 (0.64)	5~220	62~210	147 (15.0)
FTC-273(10")	46 (4691)	2500	28	9.90 (1.01)	5~260	70~250	176.5 (18.0)
FTC-310(12")	55 (5608)	2200	41	23.0 (2.35)	10~300	86~290	206 (21.0)
FTC-460(18")	65 (6650)	870	106	124(12.6)	40~410	152~436	255.0(26)
FTC-535(21")	73 (7400)	950	182	287(29.3)	45~481	155~499	313.9(32)
FTC-610B(24")	80 (8200)	850	238	488(49.8)	50~576	160~592	372.7(38)
FTC-610HA(24")	80 (8200)	850	238	488(49.8)	130~576	235~592	372.7(38)

* Specifications are subject to change without notice.

* 허용최고 회전속도는 실측치에 준함.