

HCWF 더블웨지 유압척

Double Wedge Hydraulic Chuck



HYDRAULIC CHUCK

- Available independently with two jaws which is based on double wedge type
- Ideal for variant workpieces such as rectangle, round type
- 2 JAW+2 JAW (Operated by Hydraulic system), 4 Jaw (Operated by manual system)
- 사각형, 원형, 파이프 가공뿐 아니라 직사각형, 타원형 등 이형 공작물도 가공 가능
- 유압 2+2 JAW, 매뉴얼 4JAW(더블웨지 구조로 2개조 씩 독립적으로 작동 : 유압)

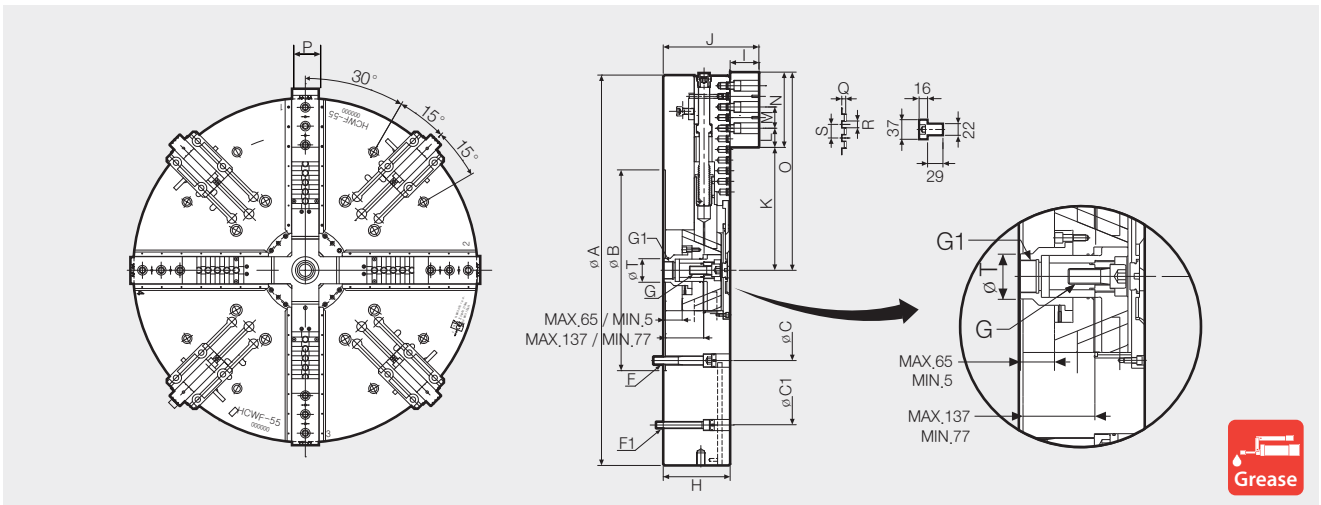

최의 오랜 수명을 유지하기 위해 최소 일 1회 이상 그리스를 주입하여 주십시오.

Dimensions / 치수표

	A	B	C	C1	D	E	F	F1	G	G1	H	I	J
HCWF-55	1400	720	647.6	1110	26	40	M30x180L	M24x170L	M30x80L	M62x2.0p	240	104	343

	K		L1		L2		M	N	O	P	Q	R	S	T
	Max.	Min.	Max.	Min.	Max.	Min.								
	250	226	65	5	137	77	76.2	270	Max. 716	85	11	19.025	38.1	110

Specifications / 사양

HCWF-55	2 Step Manual Jaw Function	Manual setting (Radial chuck Jaw)	Manual Chuck Jaw Stroke	PLUNGER STROKE (mm)	Grip. Dia.		Max. Input Force (KN)	Max. Gripping Force (KN)	Max. Speed (r.p.m.)	Weight kgf	Moment of Onetia	Operating Cylinder
					Max.	Min.						
	◎	40+(24)	60	60	1400	-	120(W1,W2)	210(J1,J2)	400	1400	355	DYV-21560

※ ◎: Option