

IAN 오토 인덱스 척

Auto-Indexing Chuck



SPECIAL CHUCK

- Machine multiple surfaces in a single clamping
- On-the-fly indexing
- Accurate, durable indexing system
- Index positions 3x120° or 4x90°
- 1회 고정 후 다양한면 가공가능
- 회전 중에도 각도 분할 기능 가능
- 3 x 120°, 4 x 90° 분할가능, 높은 분할 정밀도 보장

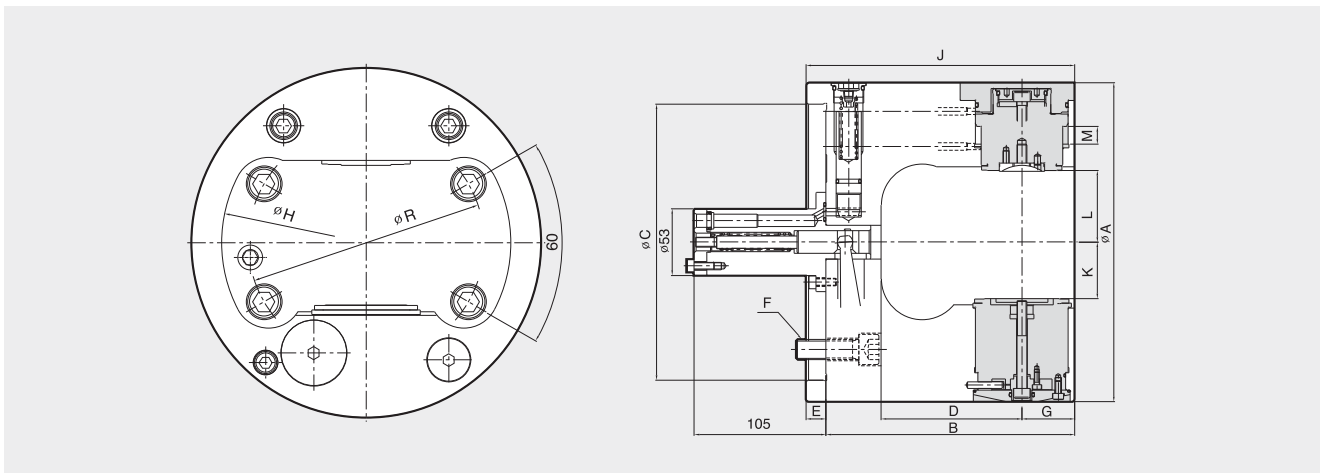

Dimensions / 치수표

	A	B	C(h ¹)	D	E	F	G	H	J	K	L	M	R
IAN-235	235	172	170	102	16	M12	30	206	188	42.5	54.5	15	133.4
IAN-254	254	198	220	112	16	M16	42	228	214	45	57	17	171.4
IAN-280	280	211	220	125	16	M16	42	250	227	58	70	17	171.4

Specifications / 사양

	Clamp Piston Area (cm ²)	Max. Pressure (kgf/cm ²)	Max. Speed (r.m.p)	Weight (kg)	GD ² (kgf·m ²)
IAN-235	30	45	3000	32	0.27
IAN-254	43	45	2500	45	0.47
IAN-280	43	45	2300	55	0.88

Indexing Position

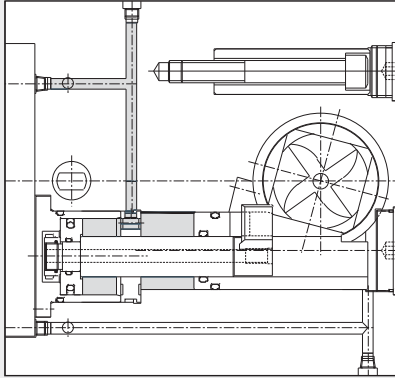

0°

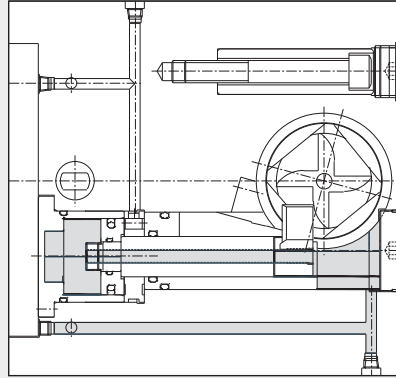

45° INDEX

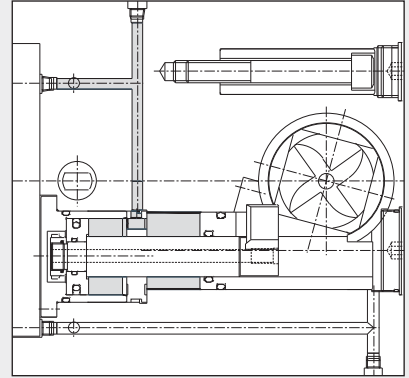

90° INDEX

Work Pieces

