

PHD 외경용 풀-다운 척

Outside Pull-Down Chuck

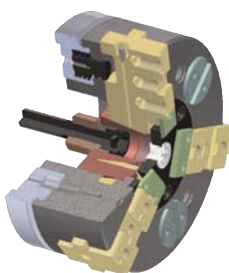

SPECIAL CHUCK



- Ideal for clamping workpieces with small gripping surfaces
- Sliding jaws clamp the component; then, the entire chuck body pulls down to location for accurate machining

- 고정 폭이 좁은 가공물의 고정에 적합
- 가공물의 우수한 평행도와 직각도

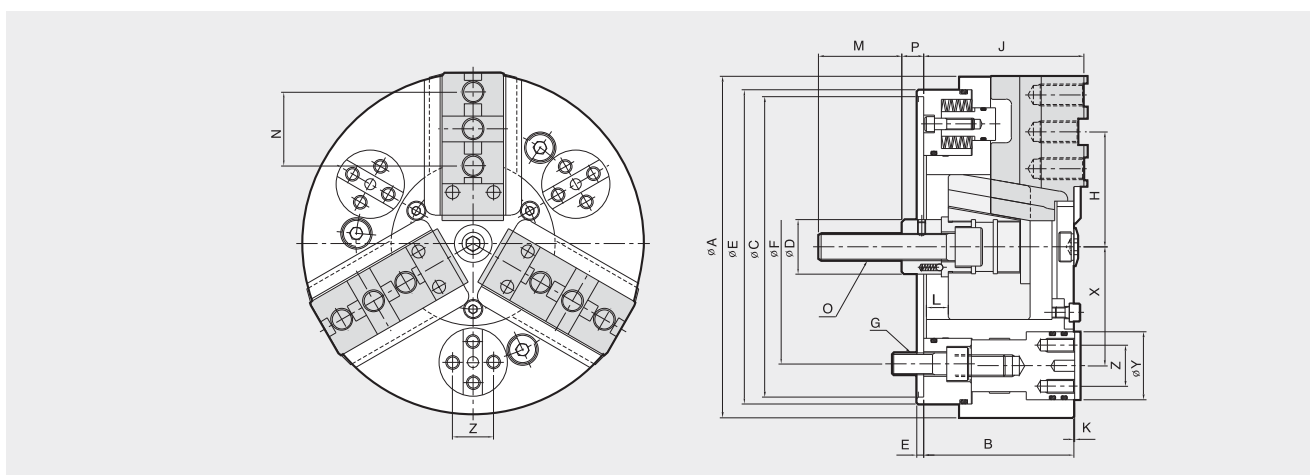

Dimensions / 치수표

	A	B	C(h ^r)	D	E	F	G	Hmax.	Hmin.	J	K	Lmax.	Lmin.	M	N	O	Pmax.	Pmin.	X	Y	Z
PHD-200	200	105	170	40	5	133.4	M12	71.5	67.3	107	1	34	10	52	44.5	M20	25	1	70	42	24
PHD-250	250	115	220	40	5	171.4	M16	87	81.7	117	1	34	4	60	54	M20	31	1	87	50	30
PHD-300	300	123	220	50	5	171.4	M16	105	99	125	1	39	5	60	63.5	M24	30	-4	108	68	40
PHD-380	380	135	300	50	5	235	M20	133.5	127.5	137	1	50	16	60	76.2	M24	19	-15	130	80	54

Specifications / 사양

	Clamping Force (kgf)	Max. Drawbar Pull (kgf)	Jaw Stroke mm(dia)	Plunger Stroke (mm)	Stop Traction (kg/f)	Max. Speed (r.p.m.)	Weight (kg)
PHD-200	8100	3000	8.5	24	200	3500	21
PHD-250	11000	4000	10.5	30	300	3000	37
PHD-300	13500	5000	12.0	34	300	2500	54
PHD-380	16500	6000	12.0	34	450	2000	95