

## Retractable-Jaw Shaft Chuck

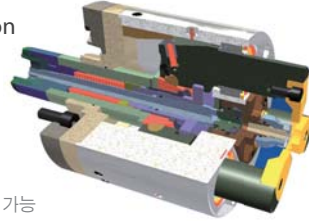

**SPECIAL CHUCK**

- Machines shafts in one single clamping operation
- Change jaws and face driver to machine different sizes of shafts



- 1회 고정 후 전체가공 가능
- 조와 페이스 드라이버 교체만으로 다양한 사이즈의 가공물 가공 가능

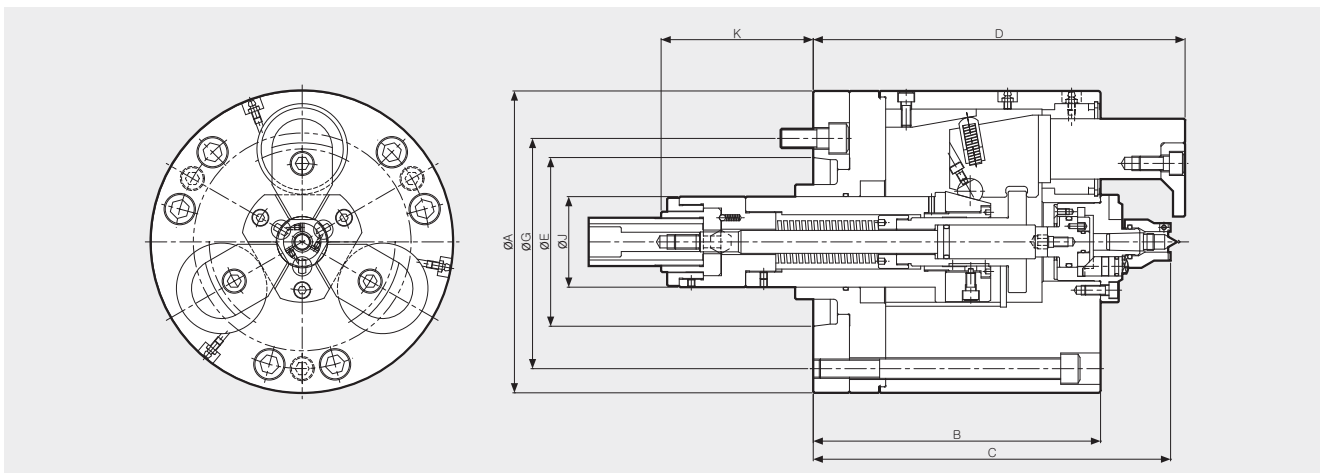

### Dimensions / 치수표

	A	Bmax.	Bmin.	C	Dmax.	Dmin.	E	G	H	J	Kmax.	Kmin.	L	M	Pmax.	Pmin.	Q	R	Smax.	Smin.	T	U	V	W
RS-200	200	164	139	192	205	180	106.375	133.4	3XM12	50	114	58	M16	30	41.5	3.5	M34X0.5	30	113	103	12.5	10	M12	30
RS-250	250	205	173.5	240	252.5	221	139.719	171.4	3XM16	60	128	63	M20	45	49.5	2.5	M40X0.5	35	123	113	16.5	10	M16	37
RS-300	300	205	173.5	240	252.5	221	139.719	171.4	3XM16	80	114.5	67.5	M24	50	49.5	2.5	M50X0.5	40	110	100	16.5	10	M16	37

### Specifications / 사양

	Clamping Force (kgf)	Max. Drawbar Pull (kgf)	Chucking Diameter (mm)		Max. Speed (r.p.m.)	Weight (kg)	GD <sup>2</sup> (kgf·m <sup>2</sup> )
			Chuck	Face Driver			
RS-200	4000	3800	18~80	12~70	4000	35	0.19
RS-250	6500	6000	25~110	12~100	3500	60	0.79
RS-300	10000	8000	40~140	30~130	2500	100	1.35